

STAINLESS STEEL TRANSOM "FREE STERN PLATFORM"

4339/4999/8998S/99 extension 2095 mm to 4395 mm

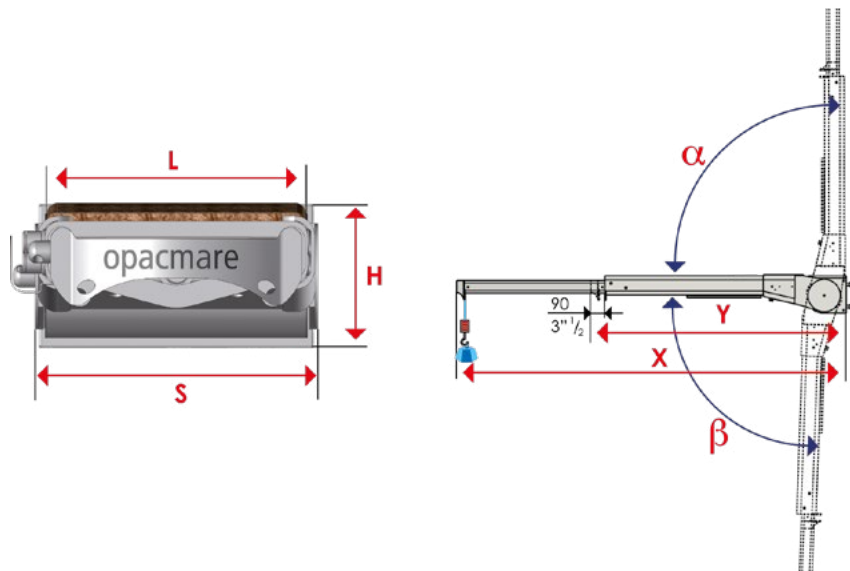
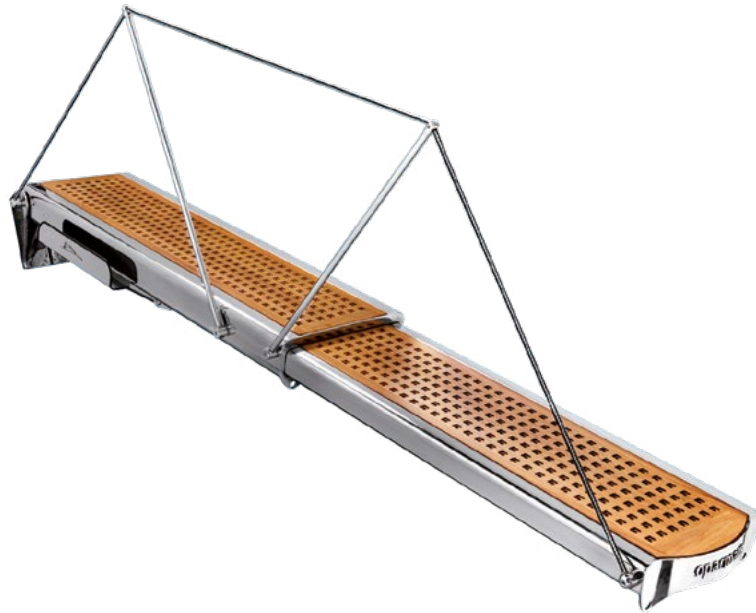

model	N. elements	X (mm/inch)	Y (mm/inch)	H (mm/inch)	L (mm/inch)	S (mm/inch)	α	β	lifting standard (kg/lbs)	lifting optional (kg/lbs)	weight (kg/lbs)
4999/20	2	2095 82" 1/2	1375 54"	220 8" 2/3	300 12"	435 17" 1/10	90°	90°	250/550	--	112/250
4999/24	2	2475 97" 2/5	1575 62"	220 8" 2/3	300 12"	435 17" 1/10	90°	90°	230/510	--	135/300
4999/27	2	2765 108" 4/5	1735 68"	220 8" 2/3	300 12"	435 17" 1/10	90°	90°	200/440	--	152/335
4999/30	2	3080 121" 1/4	1880 74"	220 8" 2/3	300 12"	435 17" 1/10	90°	90°	170/380	--	169/370
- 8998S/23	2	2330 92"	1430 56"	309 12" 1/2	340 13" 2/5	495 19" 1/2	90°	26°	450/1000	--	165/365
- 8998S/25	2	2465 97"	1485 58" 1/2	309 12" 1/2	340 13" 2/5	495 19" 1/2	90°	26°	450/1000	--	173/380
- 8998S/28	2	2785 110"	1655 65"	309 12" 1/2	340 13" 2/5	495 19" 1/2	90°	26°	450/1000	--	185/410
- 8998S/30	2	2970 117"	1970 77" 1/2	309 12" 1/2	340 13" 2/5	495 19" 1/2	90°	26°	450/1000	--	190/420
- 8998S/33	2	3280 129"	1950 77"	309 12" 1/2	340 13" 2/5	495 19" 1/2	90°	26°	450/1000	--	212/465
- 8998S/36	2	3700 145" 3/5	2150 85"	309 12" 1/2	340 13" 2/5	495 19" 1/2	90°	26°	300/660	450/1000	225/495
- 8998S/40	2	4100 161" 3/5	2400 95"	309 12" 1/2	340 13" 2/5	495 19" 1/2	90°	26°	300/660	450/1000	238/525
- 8999/26	2	2600 103"	1700 67"	250 9" 4/5	340 13" 2/5	550 21" 3/5	90°	90°	450/1000	--	239/530
- 8999/28	2	2760 109"	1780 70"	250 9" 4/5	340 13" 2/5	550 21" 3/5	90°	90°	450/1000	--	242/530
- 8999/31	2	3060 120"	1930 76"	250 9" 4/5	340 13" 2/5	550 21" 3/5	90°	90°	400/880	--	255/560
- 8999/33	2	3230 127"	2030 80"	250 9" 4/5	340 13" 2/5	550 21" 3/5	90°	90°	400/880	--	260/570
- 8999/36	2	3560 140"	2230 88"	250 9" 4/5	340 13" 2/5	550 21" 3/5	90°	90°	300/660	--	275/600
- 8999/40	2	3980 157"	2430 96"	250 9" 4/5	340 13" 2/5	550 21" 3/5	90°	90°	300/660	--	290/640
- 8999/44	2	4380 173"	2680 106"	250 9" 4/5	340 13" 2/5	550 21" 3/5	90°	90°	300/660	--	320/700
4339/22	3	2200 87"	1255 50"	220 8" 2/3	300 12"	455 17" 9/10	90°	90°	150/330	--	175/385
4339/26	3	2520 99" 1/5	1320 52"	220 8" 2/3	300 12"	455 17" 9/10	90°	90°	150/330	--	186/410
- 4339/30	3	2955 116"	1515 60"	220 8" 2/3	300 12"	455 17" 9/10	90°	90°	150/330	--	197/435
4339/35	3	3515 138"	1715 68"	220 8" 2/3	300 12"	455 17" 9/10	90°	90°	150/330	--	225/495
- 4339/39	3	3905 153" 3/4	1845 73"	220 8" 2/3	300 12"	455 17" 9/10	90°	90°	150/330	--	236/520
- 4339/44	3	4395 173"	2035 80"	220 8" 2/3	300 12"	455 17" 9/10	90°	90°	150/330	--	245/340

WITH ROTATING ACTUATOR.

This gangway allows the boarding of 150 kg / 330 lbs maximum (one person at a time).
IDEAL FOR TENDER LIFTING.

In case of stanchions, the S dimension is increased of about 50mm

NEVER USE THE GANGWAY AS SPRINGBOARD. DIVING COULD CAUSE STRONG STRAINS THAT MIGHT DAMAGE THE GANGWAY AND ITS FASTENING ELEMENTS.

- LEAD TIME TO BE CONFIRMED