

Hatches 2391.16/23

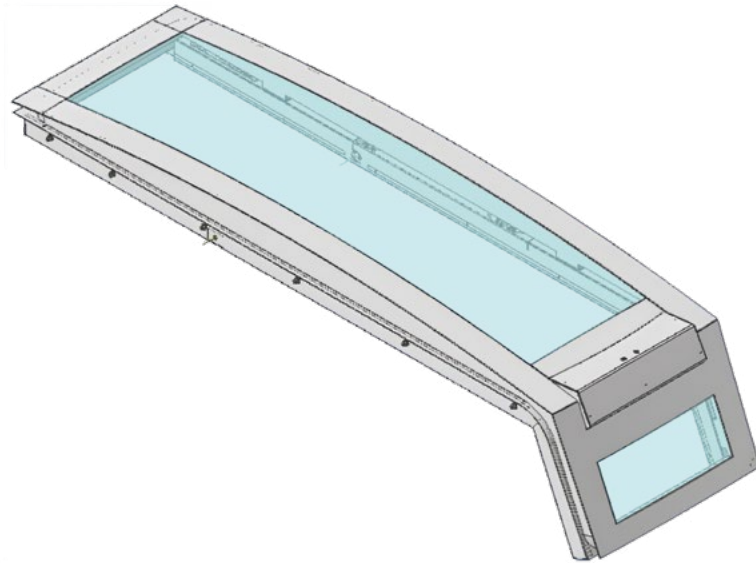

model	A (mm/inch)	B (mm/inch)	C (mm/inch)	R (mm/inch)	L (mm/inch)	H (mm/inch)	S (mm/inch)	α	weather proof ISO 12216:2023
2391/16	670 26 ³ / ₈	70 27 ⁴ / ₈	655 25 ⁷ / ₁₀	9650 379 ⁹ / ₁₀	900 35 ³ / ₈	3195 125 ³ / ₈	190 7 ¹ / ₂	37°	CAT 2
2391/23	700 27 ³ / ₈	1470 57 ⁹ / ₁₀	770 30 ³ / ₁₀	--	930 36 ³ / ₈	2775 109 ³ / ₄	155 6 ¹ / ₁₀	40°	CAT 2

Upward-opening door with AUTOMATIC movement managed by a couple of hydraulic cylinders and pantograph lever mechanism.
Tight automatic closing by means of six locking pins activated by ELECTRIC actuators.

This door can be certified in compliance with RINA/BUREAU VERITAS/LLOYDS requirements, upon request.

ATTENTION! In case of certification request, dimensions and technical specifications may undergo significant variations.

Please get in touch with our technical department to verify possible certifications.

The doors are subject to quality control tests to comply ISO 12216.2023 standards.

